

MULTIPLE CHOICE. Choose the one alternative that best completes the statement or answers the question.

Evaluate.

1) $-12 + 60 \div (-3)$ A) 32 B) -32 C) -16 D) 16 1) _____

2) $22 + 13 \cdot 22 - (-8)$ A) 278 B) 778 C) 65 D) 316 2) _____

3) $6 + 7^2 - (-5) \cdot 7$ A) 350 B) 175 C) 90 D) 20 3) _____

4) $\frac{1}{6} \div \frac{4}{5} - 6 \cdot \left(\frac{1}{2}\right)^2$ A) $-\frac{211}{24}$ B) $-\frac{139}{96}$ C) $-\frac{31}{30}$ D) $-\frac{31}{24}$ 4) _____

Evaluate the expression for the given value of the variable or variables.

5) $5x^2 + 18x$; $x = \frac{2}{5}$ A) 4 B) 8 C) 9 D) $\frac{18}{5}$ 5) _____

6) $t^2 - 2y$; $t = 8, y = -2$ A) 12 B) 20 C) 60 D) 68 6) _____

7) $a^2 - 4abc - c^2$; $a = -6, b = 3, c = 5$ A) 371 B) -349 C) 421 D) 299 7) _____

Solve the problem.

8) If the sales tax on an item is 4%, then the total cost, including sales tax, of an item costing d dollars can be found by the expression $d + 0.04d$. Determine the total costs of a camera that costs \$230. Round your answer to the nearest cent. 8) _____
A) \$236.90 B) \$322.00 C) \$241.50 D) \$239.20

9) If a rock falls from a height of 90 meters above the ground, the height, in meters, after x seconds can be found using the expression $90 - 4.9x^2$. What is the height of the rock after 4 seconds? 9) _____
A) 70.4 m B) 11.6 m C) -294.16 m D) 1361.6 m

Use the distributive property to remove parentheses.

10) $-(9x + 4y)$ A) $9x - 4y$ B) $-9x - 4y$ C) $-9x + 4y$ D) $9x + 4y$ 10) _____

Simplify.

11) $-10(6r + 7) + 10(10r + 8)$ A) $40r + 7$ B) $-130r$ C) $40r + 10$ D) $-4r - 3$ 11) _____

12) $-\left(\frac{6}{7}x - \frac{1}{10}\right) + 2x$ 12) _____
 A) $\frac{8}{7}x + \frac{1}{10}$ B) $\frac{20}{7}x + \frac{1}{10}$ C) $\frac{87}{70}x$ D) $-\frac{4}{7}x - \frac{1}{10}$

Solve the equation.

13) $13(4c - 9) = 2c - 2$ 13) _____
 A) $c = \frac{115}{54}$ B) $c = -\frac{23}{10}$ C) $c = \frac{119}{50}$ D) $c = \frac{23}{10}$

14) $8p = 7(9p + 2)$ 14) _____
 A) $p = \frac{14}{55}$ B) $p = \frac{7}{4}$ C) $p = -\frac{14}{55}$ D) $p = \frac{55}{14}$

15) $(y - 4) - (y + 8) = 5y$ 15) _____
 A) $y = \frac{3}{5}$ B) $y = -6$ C) $y = -3$ D) $y = -\frac{12}{5}$

16) $\frac{2x}{5} = \frac{x}{3} + 2$ 16) _____
 A) $x = 60$ B) $x = 30$ C) $x = -60$ D) $x = -30$

17) $\frac{3(y - 2)}{5} = 1 - 3y$ 17) _____
 A) $y = \frac{11}{18}$ B) $y = \frac{11}{6}$ C) $y = \frac{7}{6}$ D) $y = -\frac{11}{18}$

Use the formula to find the value of the variable indicated. Use a calculator to save time and where necessary, round your answer to the nearest hundredth.

18) $V = \frac{1}{3}Bh$; find h when $V = 48$ and $B = 12$. 18) _____
 A) $h = 0.33$ B) $h = 0.75$ C) $h = 0.08$ D) $h = 12$

Solve for the indicated variable.

19) $A = \frac{1}{2}bh$, for b 19) _____
 A) $b = \frac{A}{2h}$ B) $b = \frac{h}{2A}$ C) $b = \frac{2A}{h}$ D) $b = \frac{Ah}{2}$

20) $A = P(1 + nr)$, for r 20) _____
 A) $r = \frac{A - P}{Pn}$ B) $r = \frac{P - A}{Pn}$ C) $r = \frac{Pn}{A - P}$ D) $r = \frac{A}{n}$

21) $F = \frac{9}{5}C + 32$, for C 21) _____
 A) $C = \frac{F - 32}{9}$ B) $C = \frac{9}{5}(F - 32)$ C) $C = \frac{5}{9}(F - 32)$ D) $C = \frac{5}{F - 32}$

Solve the equation for y.

22) $-5x + 10y = 0$

A) $y = -2x$

B) $y = 2x$

C) $y = \frac{x}{2}$

D) $y = 2x + 5$

22) _____

Write a proportion that can be used to solve the problem. Then solve the equation to obtain the answer.

23) A bag of fertilizer covers 2500 square feet of lawn. Find how many bags of fertilizer should be purchased to cover a rectangular lawn 330 feet by 90 feet.

A) 119 bags

B) 1188 bags

C) 11 bags

D) 12 bags

23) _____

24) On an architect's blueprint, 1 inch corresponds to 4 feet. Find the length of a wall represented by a line $6\frac{1}{4}$ inches long on the blueprint. Round to the nearest tenth.

A) 25 feet

B) 6.4 feet

C) 17.5 feet

D) 156.3 feet

24) _____

Solve the inequality and graph the solution on a number line.

25) $-9x \geq 63$

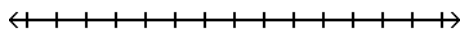

A) $x \geq -7$

B) $x \leq -7$

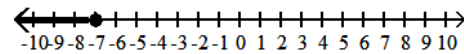
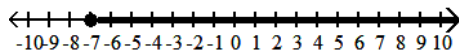

C) $x \geq 7$

D) $x \leq 7$

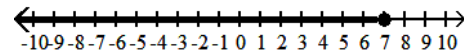
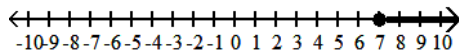

25) _____

26) $-8x - 1 > -9x - 9$

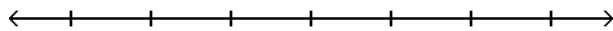

A) $x \geq -10$

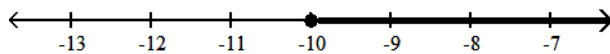

B) $x < -8$

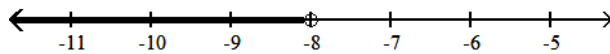

C) $x \leq -10$

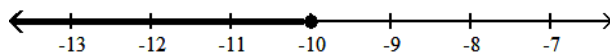

D) $x > -8$

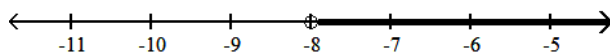

26) _____

27) $3x + 6 < 33$

27) _____

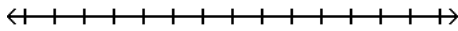

A) $x > 9$

B) $x < 9$

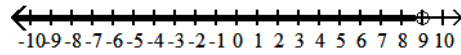
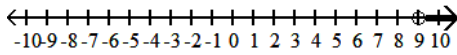

C) $x \leq 9$

D) $x \geq 9$

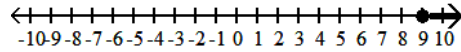
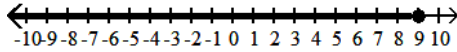

Write an equation to represent the problem.

28) Scot and Elizabeth ate dinner at an upscale bistro. The cost of their meals plus a 22% tip was \$66.98.

28) _____

A) $x + 2.2x = 66.98$

B) $x + 0.22 = 66.98$

C) $x + 0.22x = 66.98$

D) $x + 22x = 66.98$

29) Seven times a number is 12 more than two times that number.

29) _____

A) $7x = 2(x + 12)$

B) $7x + 12 = 2x$

C) $7 + x = 2x + 12$

D) $7x = 2x + 12$

30) Jennifer Park's 2007 income was 7.9% greater than her 2006 income. Her income in 2007 was \$76,600. Let i represent 2006 income.

30) _____

A) $i + 0.079i = 76,600$

B) $i + 0.079 \cdot 76,600 = 76,600$

C) $2i + 0.079i = 76,600$

D) $i - 0.079i = 76,600$

Set up an equation that can be used to solve the problem. Solve the equation and answer the question asked.

31) Five more than six times a number is that number increased by 37.

31) _____

A) $6x + 5 = x + 37; \frac{32}{5}$

B) $6x + 5 = 37x; \frac{5}{26}$

C) $6x - 5 = x + 37; \frac{42}{5}$

D) $6(x + 5) = x + 37; -\frac{18}{5}$

32) Mary and her brother John collect foreign coins. Mary has four times the number of coins that John has. Together they have 175 foreign coins. Find how many coins Mary has.

32) _____

A) 133 coins

B) 140 coins

C) 28 coins

D) 35 coins

33) When Milo got promoted at work, he received a 5% pay raise. He now earns \$71,400 per year. What was his annual salary before his raise?

33) _____

A) \$68,000

B) \$3400

C) \$71,400

D) \$3570

34) A motorcycle traveling at 60 miles per hour overtakes a car traveling at 40 miles per hour that had a three-hour head start. How far from the starting point are the two vehicles?

34) _____

A) 9 miles

B) 360 miles

C) 6 miles

D) 72 miles

35) Alexander and Judy are 29 miles apart on a calm lake paddling toward each other. Alexander paddles at 5 miles per hour, while Judy paddles at 8 miles per hour. How long will it take them to meet?

35) _____

A) 2.2 hours

B) 16 hours

C) 1.4 hours

D) 9.7 hours

- 36) At a gourmet nut shop, nuts are sold in bulk. Cashews sell for \$1.30 per pound and macadamia nuts sell for \$8.60 per pound. Lee wishes to purchase 5 pounds of mixed nuts by mixing 3.5 pounds of cashews and 1.5 pounds of macadamia nuts. What will be the price per pound of the mixture?
 A) \$6.41 B) \$3.49 C) \$32.05 D) \$17.45 36) _____

Find the slope of the line through the given points.

- 37) (-5, 9) and (8, 3)
 A) $m = \frac{6}{13}$ B) $m = -\frac{6}{13}$ C) $m = 4$ D) $m = -\frac{13}{6}$ 37) _____

- 38) (3, -6), (7, -3)
 A) $m = \frac{3}{4}$ B) $m = \frac{9}{10}$ C) $m = \frac{10}{9}$ D) $m = \frac{4}{3}$ 38) _____

Determine the slope and y-intercept of the line represented by the given equation.

- 39) $4x - 6y = 24$
 A) $m = \frac{2}{3}$; y-intercept is (0, -4) B) $m = \frac{3}{2}$; y-intercept is (0, 6)
 C) $m = 4$; y-intercept is (0, 24) D) $m = -\frac{2}{3}$; y-intercept is (0, 4) 39) _____

- 40) $y = \frac{5}{6}x - \frac{5}{2}$
 A) $m = \frac{6}{5}$; y-intercept is $(0, \frac{5}{2})$ B) $m = -\frac{5}{6}$; y-intercept is $(0, \frac{5}{2})$
 C) $m = -\frac{5}{2}$; y-intercept is $(0, \frac{5}{6})$ D) $m = \frac{5}{6}$; y-intercept is $(0, -\frac{5}{2})$ 40) _____

Determine whether the pair of lines are parallel, perpendicular, or neither.

- 41) $-5x + y = 8$
 $-5x + y + 7 = 0$
 A) parallel B) perpendicular C) neither 41) _____

- 42) $3x - 4y = -18$
 $8x + 6y = -18$
 A) parallel B) perpendicular C) neither 42) _____

Determine the equation of the line.

43)

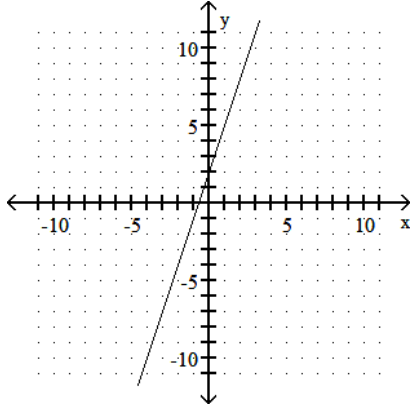

A) $y = 3x + 2$

B) $y = \frac{1}{3}x + 2$

C) $y = -3x + 2$

D) $y = 3x$

43) _____

44)

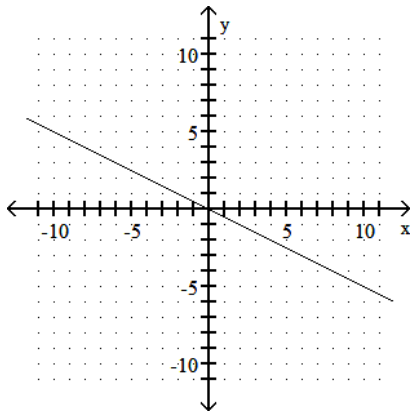

A) $y = 2x$

B) $y = -2x$

C) $y = \frac{1}{2}x$

D) $y = -\frac{1}{2}x$

44) _____

Graph by plotting points. Plot at least three points for the graph.

45) $-x + y = -1$

45) _____

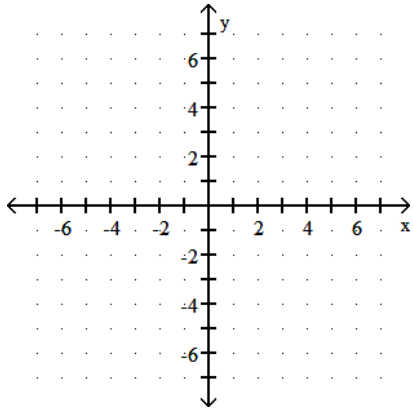

A)

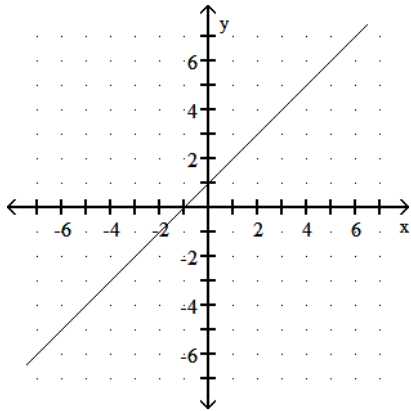

B)

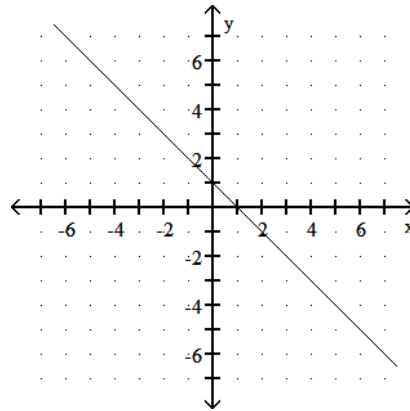

C)

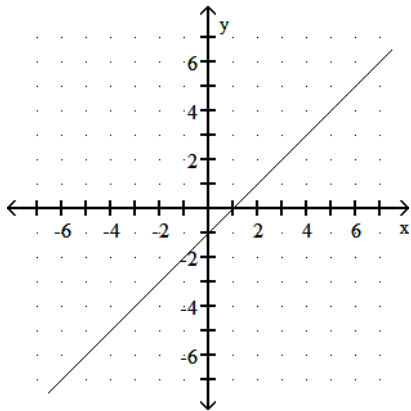

D)

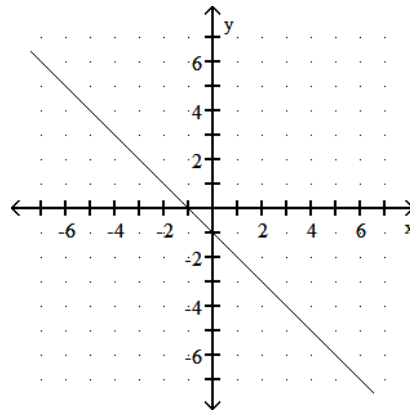

46) $3x + 2y = 10$

46) _____

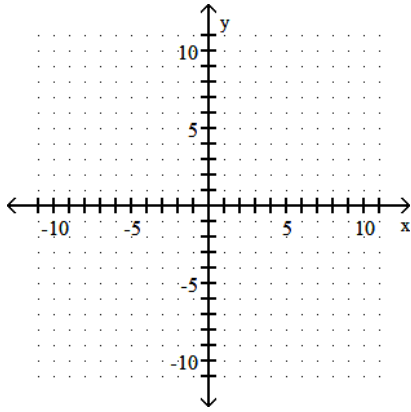

A)

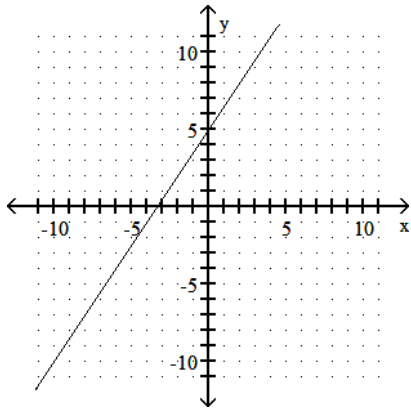

B)

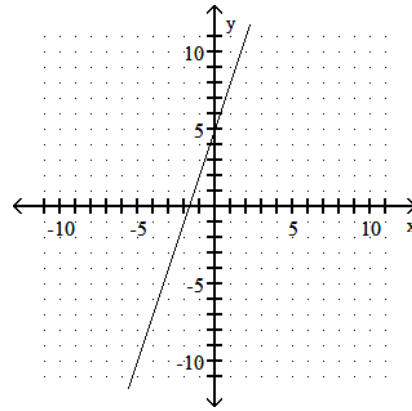

C)

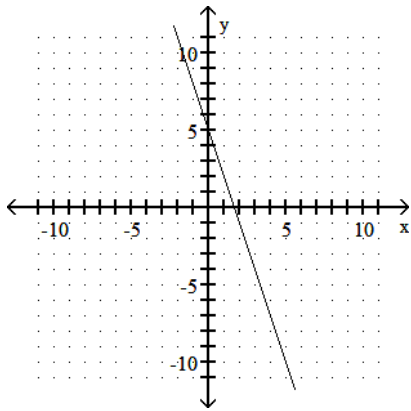

D)

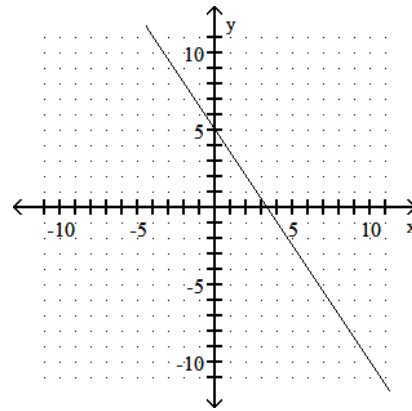

47) $y = -\frac{3}{5}x + 3$

47) _____

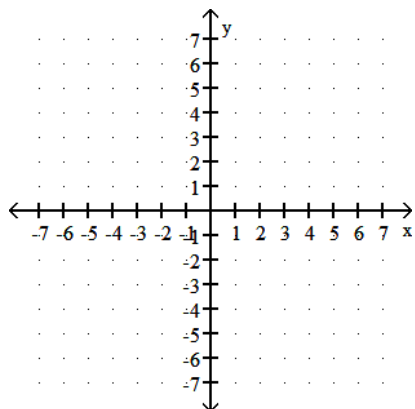

A)

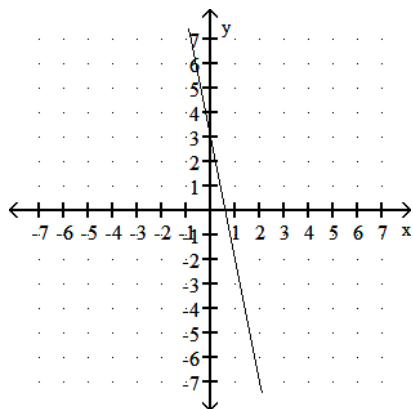

B)

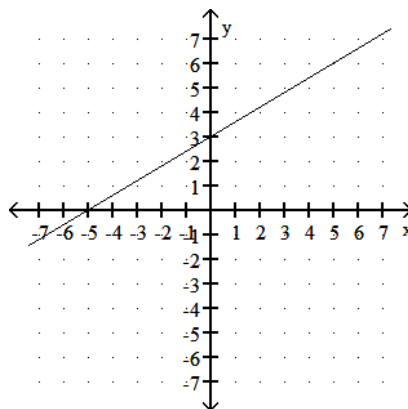

C)

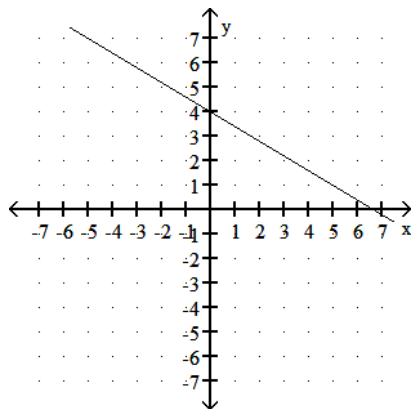

D)

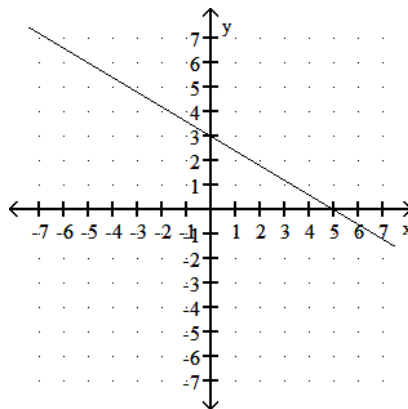

Identify the system of linear equations as consistent, inconsistent, or dependent. State whether the system has exactly one solution, no solution, or an infinite number of solutions.

48)

48) _____

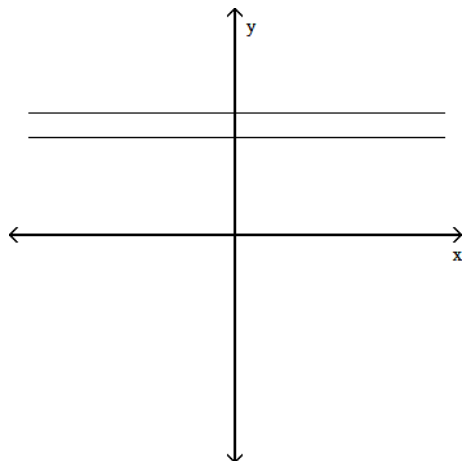

- A) consistent-one solution
- B) dependent-infinite number of solutions
- C) inconsistent-no solution

49)

49) _____

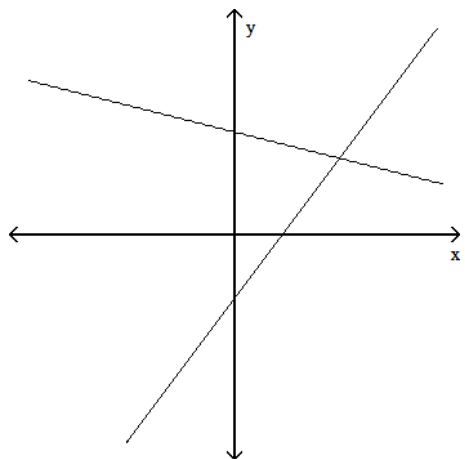

- A) inconsistent-no solution
- B) consistent-one solution
- C) dependent-infinite number of solutions

50)

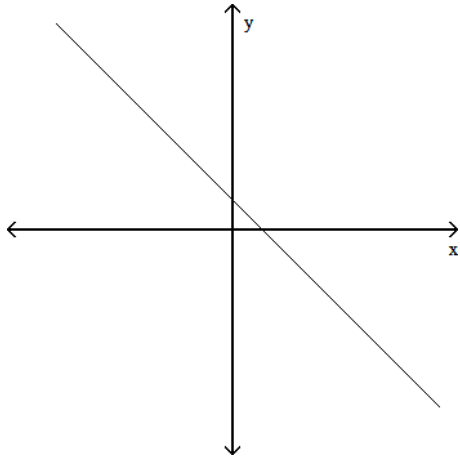

- A) inconsistent-no solution
 B) consistent-one solution
 C) dependent-infinite number of solutions

50) _____

Find the solution to the system of equations by substitution.

51) $x + y = 8$

$y = 3x$

A) $(-2, -6)$

B) $(2, -6)$

C) $(-2, 6)$

D) $(2, 6)$

51) _____

Solve the system of equations using the addition method.

52) $x - 5y = -1$

$-7x - 5y = -33$

A) $(-1, 4)$

B) $(4, 1)$

C) $(5, 0)$

D) no solution

52) _____

53) $x + 5y = 38$

$-6x + 4y = 44$

A) $(-3, 9)$

B) $(-2, 8)$

C) $(2, 9)$

D) no solution

53) _____

54) $2x + 8y = -12$

$2x + 2y = 18$

A) $(-14, 2)$

B) $(14, -5)$

C) $(-5, 14)$

D) $(-14, 8)$

54) _____

Express the exercise as a system of linear equations, then find the solution. Use a calculator where appropriate.

55) A flat rectangular piece of aluminum has a perimeter of 58 inches. The length is 9 inches longer than the width. Find the width.

A) 29 in.

B) 10 in.

C) 28 in.

D) 19 in.

55) _____

Simplify.

56) $-4z^{-3}$

A) $-\frac{64}{z^3}$

B) $-\frac{1}{64z^3}$

C) $\frac{1}{64z^3}$

D) $-\frac{4}{z^3}$

56) _____

57) $(3x - 6y8z - 8)^{-3}$

A) $\frac{x^{18}z^{24}}{-9y^{-24}}$

B) $\frac{x^{18}z^{24}}{27y^{24}}$

C) $\frac{y^{11}}{27x^9z^{11}}$

D) $\frac{y^{11}}{-9x^9z^{11}}$

57) _____

58) $\frac{(4xy-2)^{-2}}{2xy^3}$ 58) _____

A) $\frac{y}{32x^3}$ B) $-\frac{8y}{x^3}$ C) $\frac{y}{32}$ D) $-\frac{4}{x^3y^{-7}}$

Subtract.

59) $(8r^2 + 7r - 1) - (-4r^2 + 2)$ 59) _____

A) $12r^2 + 5r - 1$ B) $4r^2 + 7r + 1$ C) $12r^2 + 7r - 3$ D) $4r^2 + 5r - 1$

Add.

60) $(-5x^2 - 8x + 6) + (7x^2 - 8x - 7)$ 60) _____

A) $2x^4 - 16x^2 - 1$ B) $2x^2 - 16x - 1$ C) $2x^2 - 8x - 1$ D) $-35x^2 - 8x - 1$

Subtract.

61) $\left(3x + \frac{5}{7}\right) - \left(3x - \frac{6}{7}\right)$ 61) _____

A) $\frac{11}{7}$ B) $-\frac{11}{7}$ C) $-\frac{1}{7}$ D) $6x - \frac{1}{7}$

Multiply.

62) $2x^9(-4x^2)$ 62) _____

A) $-8x^{18}$ B) $-8x^{11}$ C) $8x^{11}$ D) $8x^{18}$

63) $(x^2 - 5x + 1)(9x)$ 63) _____

A) $9x^3 + 46x^2 + 9x$ B) $9x^3 - 44x^2 + 4x$
 C) $9x^3 - 45x^2 - 14x$ D) $9x^3 - 45x^2 + 9x$

64) $8x^4(3x^5 - 5)$ 64) _____

A) $24x^5 - 40$ B) $24x^9 - 40x^4$ C) $-16x^4$ D) $24x^9 - 5$

65) $(x + 11)(x - 5)$ 65) _____

A) $x^2 + 5x - 55$ B) $x^2 + 6x + 6$ C) $x^2 + 6x - 55$ D) $x^2 - 55x + 6$

66) $(6x + 7)(4x - 3)$ 66) _____

A) $24x^2 + 10x + 10$ B) $10x^2 + 10x + 10$ C) $24x^2 + 10x - 21$ D) $10x^2 + 10x - 21$

Multiply using a special product formula.

67) $(5p + 6)(5p - 6)$ 67) _____

A) $25p^2 - 36$ B) $25p^2 - 60p - 36$ C) $p^2 - 36$ D) $25p^2 + 60p - 36$

68) $(3x + 2.3)(3x - 2.3)$ 68) _____

A) $9x^2 - 4.6$ B) $9x^2 - 13.8x - 5.29$
 C) $9x^2 - 52.9$ D) $9x^2 - 5.29$

69) $(x - 8)^2$ _____
 A) $x^2 - 16x + 64$ B) $x + 64$ C) $x^2 + 64$ D) $64x^2 - 16x + 64$

70) $(4x + 5)^2$ _____
 A) $16x^2 + 40x + 25$ B) $4x^2 + 40x + 25$ C) $4x^2 + 25$ D) $16x^2 + 25$

Factor the GCF from each term in the expression.

71) $80x - 20$ _____
 A) $20(4x)$ B) $4(20x - 5)$ C) $20(4x - 1)$ D) $5(16x - 4)$

72) $12x^8y^7z - 20x^7y^6$ _____
 A) $4xy(3x^7y^7z - 5x^6y^5)$ B) $4x^7y^6(3xyz - 5)$
 C) $4x^7y^6z(3xy - 5)$ D) $x^7y^6(12xyz - 20)$

73) $8m^9 - 14m^6 + 20m^2$ _____
 A) No common factor B) $2m^2(4m^7 - 7m^4 + 10)$
 C) $m^2(8m^7 - 14m^4 + 20)$ D) $2(4m^9 - 7m^6 + 10m^2)$

Factor the polynomial. If the polynomial is prime, so state.

74) $x^2 + 6x - 16$ _____
 A) $(x + 8)(x - 2)$ B) $(x - 8)^2$ C) $(x - 8)(x - 2)$ D) prime

75) $40 + 39x + x^2$ _____
 A) $(x + 40)(x + 1)$ B) $(x + 40)(x - 1)$ C) $(x + 8)(x + 5)$ D) prime

Factor completely. If the polynomial is prime, so state.

76) $15x^2 + 22x + 8$ _____
 A) $(3x - 2)(5x - 4)$ B) $(3x + 2)(5x + 4)$ C) $(15x + 2)(x + 4)$ D) prime

77) $6x^2 - x - 22$ _____
 A) $(6x + 2)(x - 11)$ B) $(6x - 11)(x + 2)$ C) $(6x + 11)(x - 2)$ D) $(6x - 2)(x + 11)$

Solve.

78) $90n^2 + 78n = 0$ _____
 A) $-\frac{13}{15}, 0$ B) $-\frac{13}{15}, 78$ C) $-\frac{13}{15}$ D) 0

79) $x^2 + 2x - 24 = 0$ _____
 A) -6, 4 B) 6, -4 C) 6, 4 D) -6, 1

80) $2x^2 - 9x = 5$ _____
 A) $-\frac{1}{2}, 2$ B) $-\frac{1}{2}, 5$ C) $\frac{1}{9}, -\frac{1}{2}$ D) -2, 5

81) $(x + 4)^2 = 4$ _____
 A) -4 B) -6 C) 6, 2 D) -6, -2

Solve the problem.

- 82) If the sides of a square are increased by 2 meters, the area becomes 100 square meters. Find the length of a side of the original square. 82) _____
A) 12 m B) 10 m C) 2 m D) 8 m

- 83) The cost C of manufacturing x units of a certain product is given by $C = x^2 - 10x + 1200$. Find the number of units manufactured at a cost of \$6800. 83) _____
A) 80 units B) 30 units C) 40 units D) 70 units

Add or subtract.

- 84) $\frac{5y}{b} + \frac{9b}{2}$ 84) _____
A) $\frac{5y + 9b}{2b}$ B) $\frac{10y + 9b^2}{2b}$ C) $\frac{10y + 9b}{2b}$ D) $10y + 9b^2$

- 85) $\frac{42}{7x} + \frac{48}{6x}$ 85) _____
A) $\frac{14}{x}$ B) $\frac{14}{2x}$ C) $\frac{588}{42x}$ D) $\frac{14}{x^2}$

- 86) $\frac{3}{x+7} + 8$ 86) _____
A) $\frac{8x + 59}{x + 7}$ B) $\frac{11}{x + 7}$ C) $\frac{8x + 77}{x + 7}$ D) $\frac{8x + 53}{x + 7}$

Solve the equation and check your solution.

- 87) $\frac{2x}{9} + 5 = \frac{1}{2}$ 87) _____
A) $x = -\frac{89}{4}$ B) $x = -\frac{81}{4}$ C) $x = \frac{9}{2}$ D) $x = \frac{93}{4}$

- 88) $\frac{x - 4}{6} = \frac{x + 2}{4}$ 88) _____
A) $x = -14$ B) $x = \frac{2}{3}$ C) $x = 5$ D) $x = \frac{7}{6}$

- 89) $5 + \frac{2}{x} = \frac{15}{4}$ 89) _____
A) $x = \frac{8}{11}$ B) $x = \frac{8}{5}$ C) $x = -\frac{8}{35}$ D) $x = -\frac{8}{5}$

- 90) $\frac{2}{t} = \frac{t}{5t - 12}$ 90) _____
A) $t = 0, t = \frac{24}{9}$ B) $t = 4, t = 6$ C) $t = 0, t = 36$ D) $t = 0$

Solve the problem and answer the question.

91) A car travels 400 miles on level terrain in the same amount of time it travels 160 miles on mountainous terrain. If the rate of the car is 30 miles per hour less in the mountains than on level ground, find its rate in the mountains. 91) _____

- A) 40 mph B) 50 mph C) 80 mph D) 20 mph

92) A barge takes 5 hours to move (at a constant rate) downstream for 55 miles, helped by a current of 3 miles per hour. If the barge's engines are set at the same pace, find the time of its return trip against the current. 92) _____

- A) 5 hr B) 110 hr C) 11 hr D) 8 hr

93) One pump can drain a pool in 12 minutes. When a second pump is also used, the pool only takes 9 minutes to drain. How long would it take the second pump to drain the pool if it were the only pump in use? 93) _____

- A) 105 min B) $\frac{1}{36}$ min C) 36 min D) $5\frac{1}{7}$ min

94) A baker can decorate the day's cookie supply four times as fast as his new assistant. If they decorate all the cookies working together in 20 minutes, how long would it take for each of them to decorate the cookies working individually? 94) _____

- A) baker: 100 min
assistant: 400 min B) baker: 100 min
assistant: 25 min
- C) baker: 25 min
assistant: 100 min D) baker: $6\frac{1}{4}$ min
assistant: 25 min

Simplify.

95) $\sqrt{x^8}$ 95) _____

- A) x^6 B) x^4 C) $\frac{x^4}{2}$ D) x^{16}

96) $\sqrt{150x^2}$ 96) _____

- A) $5\sqrt{6x^2}$ B) $5\sqrt{6}$ C) $5x\sqrt{6}$ D) $5x^2\sqrt{6}$

97) $\sqrt{x^4y^5z^6}$ 97) _____

- A) $x^2y^2z^2\sqrt{yz^3}$ B) $x^2y^3z^4$ C) $x^2y^2z^3\sqrt{y}$ D) $x^2z^3\sqrt{y^5}$

Simplify the expression.

98) $6\sqrt{5x} + 2\sqrt{5x}$ 98) _____

- A) $8\sqrt{5x}$ B) $4\sqrt{5}$ C) $8x\sqrt{10}$ D) $12\sqrt{10x}$

99) $-3\sqrt{5} - 6\sqrt{45}$ 99) _____

- A) $21\sqrt{5}$ B) $6\sqrt{5}$ C) $-21\sqrt{5}$ D) $-9\sqrt{5}$

100) $\sqrt{5a} - 3\sqrt{180a} - 4\sqrt{80a}$ 100) _____

- A) $-7\sqrt{265a}$ B) $-33\sqrt{265a}$ C) $-7\sqrt{5a}$ D) $-33\sqrt{5a}$